

ROTARY SWITCHES

TYPE DJ 10 or 12 position

FEATURES

- Gold contacts for electrical stability
- Long operational life
- Balanced positive indexing
- 100% electrically tested
- Stainless steel spindles
- Wide operating temperature range



TECHNICAL SPECIFICATION

Electrical Specifications

Contact Rating:- Switching	5VA dc. 10VA ac. (250mA max) resistive
Continuous	2A
Proof Voltage (for 1 min.)	750 V peak, adjacent term
Insulation Resistance	1000M Ω min at 500 volts dc.
Contact resistance (at terminals)	100m Ω max initially measured at 100mV, 100mA. after 10,000 cycles max increase from initial value 20m Ω
Capacitance	3pf adjacent terminals
Endurance	10,000 cycles at upper temp category (85 $^{\circ}$) & VA rating

Mechanical Specifications

Temperature Range	-40 $^{\circ}$ C/+85 $^{\circ}$ C
Contact Finish	Gold on nickel
End Stop Strength	0.5Nm
Terminal Strength	Tensile test load 5N
Sealing	Spindle & panel seal option max. leakage 1ml/hour.
Mounting Bush	Brass nickel plated
Spindle	Stainless steel or mild steel nickel plated
Operating Torque	.04/.10Nm
Index Body	Glass filled nylon 66
Stator	High grade epoxy glass laminate
Endurance	10,000 cycles
Terminals	Brass silver plated

Dimensions in mm

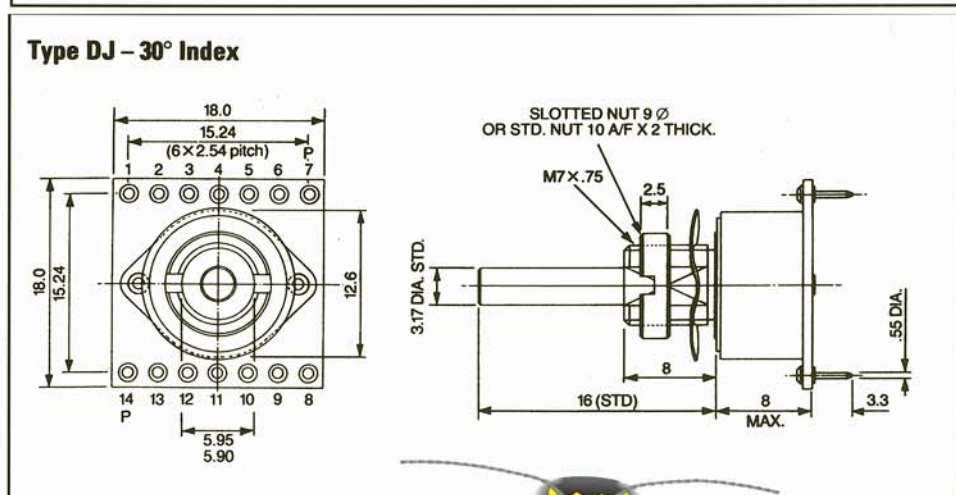
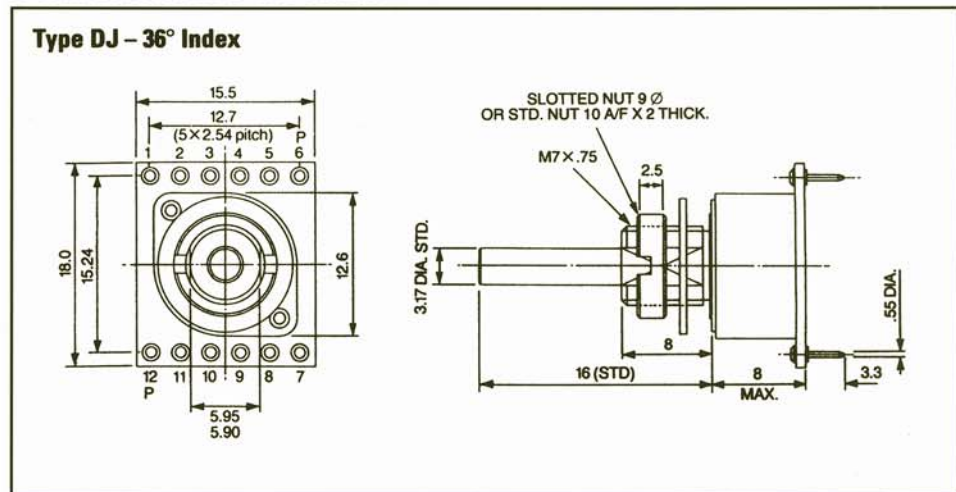

Wessex Advanced Switching Products Ltd
 Alexandria Park, Penner Road Havant,
 Hants PO9 1QY, UK
 Tel: +44 (0)239 245 7000
 Fax: +44 (0) 239 247 3918
 email: sales@wasp-ltd.co.uk
 www.waspswitches.co.uk

